

USER AND INSTALLATION MANUAL

MAG:CFX®

ENGLISH

/ECO2JET®



CE SMOKE FX

PART02302
REV 01-01

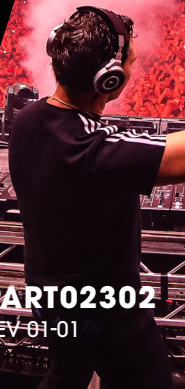

DISCLAIMER

⚠ WARNING

Read this manual carefully before installing and/or using this product. Failure to read the manual and to follow the printed instructions may lead to personal injury and/or damage to the product.

© 2024 MAGICFX®

All rights reserved.

Nothing from this publication may be copied, reproduced and/or published by means of printing, photocopying or by any other means, without the prior written approval of MAGIC FX.

MAGIC FX reserves the right to modify specifications stated in this manual.

TRADEMARKS

Any brand names mentioned in this manual are registered trademarks of their respective owners.

LIABILITY

MAGIC FX accepts no liability for claims from third parties arising from unauthorised use, use other than that stated in this manual, and use other than in accordance with the General Conditions registered at the Chamber of Commerce.

We further refer to the General Conditions. These are available on request, free of charge.

Although considerable care has been taken to ensure a correct and comprehensive description of all relevant components, the manual may nonetheless contain errors and inaccuracies.

Should you detect any errors or inaccuracies in the manual, we would be grateful if you would inform us. This helps us to further improve our documentation.

TABLE OF CONTENT





Introduction	4
Language	4
Abbreviations	4
Revision table	5
1. Description	5
1.1. Main parts	6
1.2. Technical data	7
1.3. Product identification	8
1.4. FX fluids	8
1.5. Accessories	9
1.6. DMX control	10
1.7. Display panel	12
1.8. RDM capability	15
2. Safety	17
2.1. General safety rules	17
2.2. Indoor & outdoor use	17
2.3. Rigging	18
2.4. Noise levels	18
2.5. Safety symbols	18
2.6. Safety warnings	18
3. Installation and use	21
3.1. Mount on a stage	21
3.2. Mount on a truss	22
3.3. (Re)place the fluid can	28
3.4. Mount the Attachable Fluid Can	29
3.5. Connect DMX and power	30
3.6. Setting the heat-up power mode	30
3.7. Prime the ECO2JET®	31
3.8. Blast with DMX	31
3.9. Clean up	33
4. Troubleshooting	34
5. Maintenance	36
5.1. Replace the air filter	36
5.2. Replace the fluid mesh filter	37
6. Correct disposal	38
7. EC Declaration of Conformity	39

INTRODUCTION

Congratulations! You have bought a great new product from MAGIC FX.

This manual contains all information required for the intended use of the equipment. Deviation from the described intended use can result in a hazardous situation and/or property damage.

This manual includes notes and warnings on safe operation of the equipment. These notes and warnings are accompanied by the following icons. Read them attentively!

 DANGER	Indicates a hazardous situation that, if not avoided, will result in death or serious injury. This signal word is to be limited to the most extreme situations.
 WARNING	Indicates a hazardous situation that, if not avoided, could result in death or serious injury.
 CAUTION	Indicates a hazardous situation that, if not avoided, could result in minor or moderate injury.
 NOTICE	Indicates information considered important, but not hazard-related (e.g. messages relating to property damage).

LANGUAGE

This document contains the original instructions in English. In case you require other languages please contact MAGIC FX.

ABBREVIATIONS

Abbreviation	Description
SFX	Special effects
DMX	Digital Multiplex
RDM	Remote Device Management
ECO2JET®	MAGICFX® ECO2JET®
ECO2JET® Bracket	MAGICFX® ECO2JET® Bracket
Attachable Fluid Can	MAGICFX® ECO2JET® 2L Attachable Fluid Can
Omega Brackets	MAGICFX® Omega Bracket (C-T-C 140 mm) - Set of 2
OUTDOOR FLUID	MAGICFX® ECO2JET® Outdoor Fluid 5L
INDOOR FLUID	MAGICFX® ECO2JET® Indoor Fluid 5L

Abbreviations

REVISION TABLE

Doc nr	Revision	Date	Description	Author	Approved
PART02302	01-00	28-03-2024	Initial release	MBO	RD
PART02302	01-01	02-05-2024	Updated voltage	MBO	TH

1. DESCRIPTION

The ECO2JET® is a special effects device designed to produce white plumes of smoke resembling a CO₂ effect, but without the need for CO₂. This innovative machine offers improved safety, durability, and ease of use compared to traditional CO₂ effects machines.

Comprised of three primary components – a pump, heater, and fan – the ECO2JET® operates using a specially formulated fluid, stored in an external fluid can. This fluid can can be rapidly connected to the machine via a convenient quick connector. With the ability to extend the hose horizontally and vertically up to 2 meters, users can store the liquid safely and accessibly.

The pump draws the fluid into the machine's heater, where it undergoes vaporization. The resulting vapor is then forcefully propelled into the air by a high-speed fan, creating the desired visual effect. The effect can be propelled up to 12 meters.

Equipped for compatibility with DMX and RDM systems, the ECO2JET® can be seamlessly integrated into complex setups and used in tandem with multiple machines. Additionally, the ECO2JET® offers two distinct heat-up power modes, allowing users to adapt the machine's operation to the available power source.

With its innovative design and versatile functionality, the ECO2JET® represents a safer, more efficient alternative to traditional CO₂ effects machines, making it ideal for a wide range of applications in the entertainment industry.

1.1. MAIN PARTS

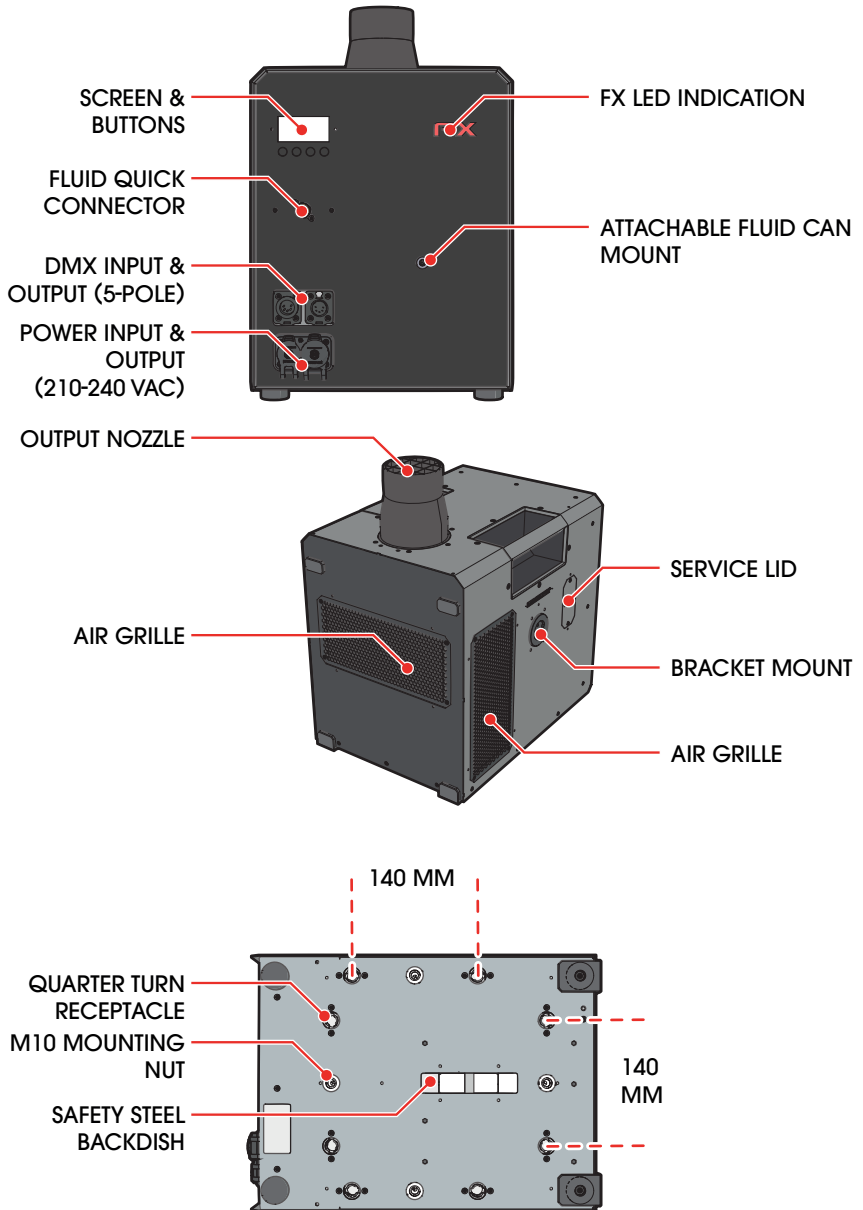

Main parts

1.2. TECHNICAL DATA

Product	Product Name	ECO2JET®	
	Product Code	MFX1801	
	Product Type	SMOKE FX	
Main Dimensions	Length	407 mm	16 in
	Width	291 mm	11.5 in
	Height	468 mm	18.4 in
Weight	Empty Weight	30.5 kg	67.2 lbs
	Packaged Weight	31.7 kg	69.9 lbs
Environment	Minimum Temperature	- 10 °C	23 °F
	Maximum Temperature	50 °C	122 °F
	Humidity (Relative)	20 to 90 % (non-condensing)	
Electrical	Voltage Input	210 - 240 VAC	
	Voltage Frequency	50 - 60 Hz	
	Heat-up Power	1.5 kW (ECO) 3.5 kW (FULL)	
	Idle Power *	140 W	
	Power Connector	Neutrik® powerCON TRUE1 (in&out)	
Controlling	Control Options	DMX Menu: Test Mode	
	Control Protocols	DMX512-A (ANSI E1.11) RDM (ANSI E1.20)	
	Control Connectors	Neutrik® 5-pole male/ female XLR	
Configuring	Configure Options	On Device RDM	
Usage	Consumable(s)	MAGICFX® ECO2JET® Outdoor Fluid 5L MFX3090 MAGICFX® ECO2JET® Indoor Fluid 5L MFX3091	
	Consumable Consumption	0.38 L/min	2.6 min/L

Technical data

* These values are a computed average measured over a longer period of time after the device has finished its initial heating.

1.3. PRODUCT IDENTIFICATION

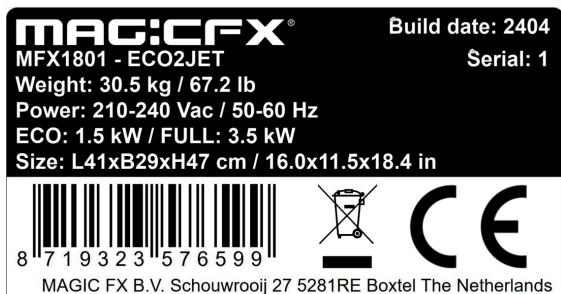

Type plate

1.4. FX FLUIDS

The ECO2JET® uses dedicated fluids from MAGIC FX to create plumes of white smoke. The fluids are available in 5L fluid cans. The fluid can is placed outside the ECO2JET® and connected with the ECO2JET® Fluid Can Lid Assembly (ASS90100) or through a MAGICFX® ECO2JET® Fluid Extension Hose (MFX1805 or MFX1806). Alternatively, the fluid can be poured into an Attachable Fluid Can (MFX1803), which can be mounted with an M6 nut on the ECO2JET®.

⚠ WARNING

Do not use other fluids than those that are approved and supplied by MAGIC FX, see the following table. Always follow the instructions as noted on the fluid can. The warranty is void if other fluids are used.

Code	Type of fluid	Volume
MFX3090	MAGICFX® ECO2JET® Outdoor Fluid	5 L
MFX3091	MAGICFX® ECO2JET® Indoor Fluid	5 L

FX fluids

1.5. ACCESSORIES

Code	Product	Included
MFX1802	MAGICFX® ECO2JET® Bracket	
MFX1803	MAGICFX® ECO2JET® 2L Attachable Fluid Can	
MFX1804	MAGICFX® Omega Bracket (C-T-C 140 mm) - Set of 2	
MFX1805	MAGICFX® ECO2JET® Fluid Extension Hose 1 m	
MFX1806	MAGICFX® ECO2JET® Fluid Extension Hose 2 m	
MFX1807	MAGICFX® ECO2JET® Flightcase (for 2 pcs)	
MFX0313	Schuko to Neutrik® powerCON TRUE1 cable - 1.5 m	
MFX3104	Doughty Quick Trigger Clamp (100 kg) M10	
MFX3106	Doughty Half Coupler (100 kg) M10	
ASS90100	Fluid Can Lid Assembly	1x
PART02402	Fluid Mesh Filter G 1/4"	1x
ASS02427	Air Filter for ECO2JET® (set of 3)	1x
MFX3109	MAGICFX® 5L Fluid Can Bracket	

Accessories

Please contact MAGIC FX for additional possibilities.

1.6. DMX CONTROL

1.6.1. STANDARD PERSONALITY

When connected to DMX the ECO2JET® is controlled with 1 safety address and 1 operational addresses in the standard personality:

DMX Address	Address range	Control
Enable address	1-512	Device enable / disable
Start address	1-512	Effect trigger

DMX Addresses

NOTICE

The enable address cannot be the same as the operational address.

Operating of these addresses results in the following:

DMX Value Enable Ch.	DMX Value Start Ch.	Result		
Lower bound	Upper bound			
0	24			
25	64	Hold ≥ 3s: Reset locking errors		
65	99	Device pre-enabled System pressurised		
100	154	0	199	Device enabled System pressurised, fan spin-up
		200	255	Output effect
155	199			
200	255	0	99	
		100	154	Prime
		155	255	

It is advised to use prime mode in the following situations:

- A new or empty 2m ECO2JET® Fluid Extension Hose (MFX1805) is used in the setup.
- The device is at a +1m height difference with the fluid can.

When you link multiple machines with DMX, we advise you to use the same enable address for all machines.

CAUTION

The system is pressurized when pre-enabled, enabled and during effect output.

CAUTION

Once enabled, the fan inside the ECO2JET® starts spinning.

NOTICE

Smoke will come from the machine during priming.

NOTICE

With both heat-up power modes, the maximum continuous duration of the effect is 8 seconds. After this period, the effect will stop automatically. To start the effect again you must reset the effect trigger.

NOTICE

Keep in consideration that during the effect the heater will cool down and the interval between two equal effect durations not only depends on the effect time used, but also on the set heat-up power mode.

1.6.2. EXTENDED PERSONALITY

When connected to DMX the ECO2JET® is controlled with 1 safety address and 2 operational addresses in the extended personality:

DMX Address	Address range	Control
Enable address	1-512	Device enable / disable
Start address	1-511	Effect trigger
Start address + 1	2-512	Heater

DMX Addresses

NOTICE

The addresses cannot conflict with each other.

Operation of the extended mode is equal to the standard mode with the addition of one heater channel:

DMX Value Heater Ch.		Result
Lower bound	Upper bound	
0	99	
100	154	Hold ≥ 3s: Heater off
155	199	
200	255	Hold ≥ 3s: Heater on

NOTICE

When the heater is disabled the system cannot be pressurized or fired.

NOTICE

Always plug in a DMX Terminator into the DMX output of the final unit in the control sequence. Using a DMX Terminator improves signal reliability.

1.7. DISPLAY PANEL

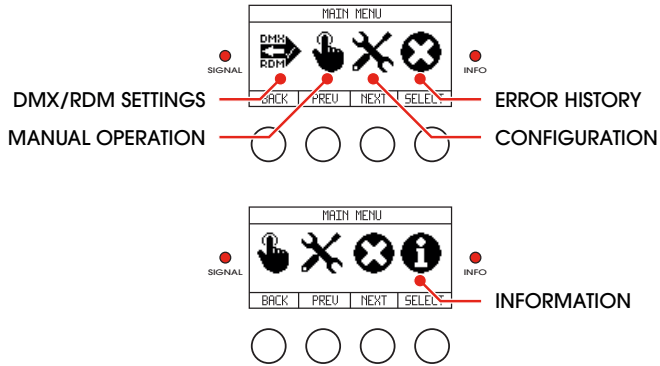

Display panel

The display panel is located on the backside of the ECO2JET®. Check the following menu structure for all options in the menu. Use the buttons for navigation and selection. The signal LED blinks red when DMX signal is active. The info LED continuously lights red when an error is present.

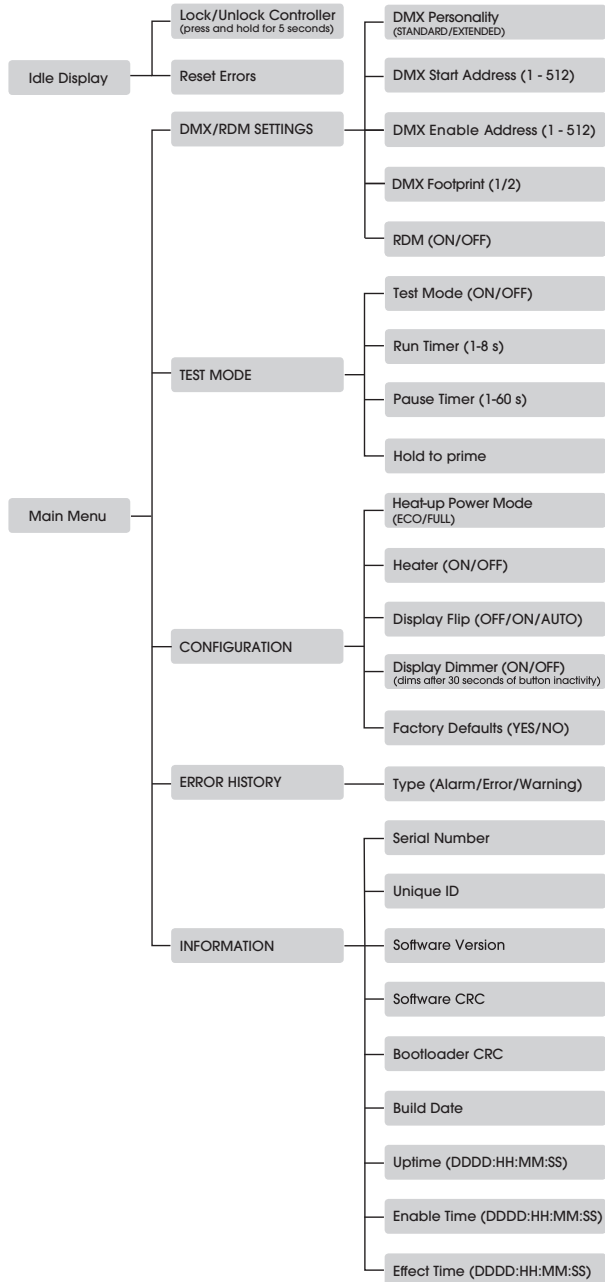

Menu structure

Menu function	Explanation
Lock/Unlock Controller	Holding the Lock button for more than 5 seconds will "lock" the display functions. Meaning buttons will not respond. This to avoid accidental change of parameters via display. To unlock, hold the Unlock button for more than 5 seconds. In case system is armed display is locked.
Reset Errors	In case there is a locking error present, this button will reset the appliance. If the fault does not persist, the locking error will not reappear.
DMX Personality (STANDARD/ EXTENDED)	Set the DMX personality to standard (enable & start channel) or extended (enable & start + heater channel)
DMX Start Address (1-512)	Setting the DMX start address.
DMX Enable Address (1-512)	Setting the DMX Enable Address.
DMX Footprint	This parameter indicates the DMX footprint, in other words the amount of sequential channels used by the appliance. This does not include the enable channel.
RDM (On/Off)	Use this function to turn on/off the RDM functionality.
Test Mode (ON/OFF)	Enable the Test Mode. The device will start the effect after 3 seconds. The effect will run 1 - 8 seconds set in the run timer. The device then pauses for 1-60 seconds set in pause timer.
Run Timer (1-8 s)	Set the duration of the effect in Test Mode.
Pause Timer (1-60 s)	Set the duration of the pause between effects in in Test Mode.
Hold to prime	Hold the prime button to manually prime the device.
Heat-up Power Mode (ECO/FULL)	Use this function to toggle between different heat-up power modes: ECO (1500 W), FULL (3500 W)
Heater (ON/OFF)	Enables or disables the heater. This setting can also be set using the DMX heater channel when in EXTENDED mode, or by RDM.
Display Flip	Change the display orientation from normal to upside down. In auto mode the machine automatically adjusts the display orientation to the position.
Display Dimmer (On/Off)	Turn display dimmer on or off. If turned on, the display is dimmed automatically 30 seconds after the last button push.
Factory Defaults (Yes/No)	Restores the appliance factory default settings.

Menu functions

Menu function	Explanation
Category (Alarm/Error/Warning)	Switch between the current locking errors (Alarm), blocking errors (Error), and warnings. Locking errors can be reset by the user, through the menu or using DMX. Blocking errors clear themselves once the triggering fault disappears. A total of 16 locking errors, 16 blocking errors and 16 warnings are logged. The most recent error is displayed at the top of the list.
Serial Number (DDDDD)	Appliance serial number as also printed on the appliance label.
Unique ID (HHHHHHHHHHH)	UID number as the appliance appears in the RDM device list after running discovery.
Software Version	Installed software version.
Software CRC	CRC of the functional software.
Bootloader CRC	CRC of the bootloader software.
Build Date	Release date of functional software.
Uptime (DDDD:HH:MM:SS)	Time counter which indicates how long the appliance has been powered in total.
Enable Time (DDD:HH:MM:SS)	Time counter which indicates how long the appliance has been enabled in total.
Effect Time (DDDD:HH:MM:SS)	Time counter which indicates how long the effect has been on in total.

Menu functions

⚠ WARNING

Keep all safety precautions in mind when operating Test Mode.

1.8. RDM CAPABILITY

Remote Device Management Protocol (RDM) is an enhancement of the DMX512 communication protocol. RDM can be used for configuration and status monitoring while DMX512 takes care of the default controlling.

For RDM you will need an RDM compatible controller.

The following RDM parameters are supported by the ECO2JET®.

Parameter ID	Discovery	GET	SET
DISC_UNIQUE_BRANCH	X		
DISC_MUTE	X		
DISC_UN_MUTE	X		
DEVICE_INFO		X	
SUPPORTED_PARAMETERS		X	
PARAMETER_DESCRIPTION		X	
SOFTWARE_VERSION_LABEL		X	
DEVICE_MODEL_DESCRIPTION		X	
MANUFACTURER_LABEL		X	
SLOT_DESCRIPTION		X	
SENSOR_DEFINITION		X	
SENSOR_VALUE		X	
DMX_START_ADDRESS		X	X
IDENTIFY_DEVICE		X	X
DEVICE_LABEL		X	X
DISPLAY_INVERT		X	X
RDM_PID_SET_ENABLE_ADDR		X	X
RDM_PID_HEATER_ENABLE		X	X
FACTORY_DEFAULTS		X	X
RESET_DEVICE			X

RDM parameters

RDM parameters are subject of change due to software updates. Contact MAGIC FX for the latest information and updates.

The following sensors are available through RDM:

Sensor	Description
Heating percentage	The heater percentage is displayed to indicate the status of the heater. It represents the progress of the heat-up process. Once the device is ready, the percentage reflects the remaining effect time.
Error code	0 = no error. All other numbers indicate an error.
Prime finished	0 = no 1 = yes

2. SAFETY

The ECO2JET® has been designed and constructed in such a manner that it can be used safely. This applies to the use, the circumstances and the regulations as described in this documentation. Reading this documentation and following the instructions are therefore necessary for everyone who is authorised to work with the ECO2JET®.

The ECO2JET® must be used in surroundings that:

- Have a reasonably stable temperature of between -10 and 50 °C.
- Have a relative humidity degree between 20 % and 90 % (non condensing).
- Are free of dust, corrosive gases and high concentrations of organic vapours.
- Are free of chlorine fumes.
- Are not situated in the vicinity of a source of vibration.

NOTICE

Do not place the ECO2JET® on top of subwoofers. This may cause internal damage to the machine.

2.1. GENERAL SAFETY RULES

- Only authorised persons may work with the ECO2JET®.
- Do not use the ECO2JET® if there are people or animals in the direct output.
- Make sure that children, unauthorised people and animals do not obtain access to the ECO2JET®.
- Make sure there are no freestanding objects or objects that can be damaged by the ECO2JET® within the output distance.
- Do not connect more units to a single electrical circuit than the installed fuse is able to handle. (Calculate the summed load with the electrical data from Chapter 1).
- Do not remove or bypass any safeguards and safety symbols.
- All required safety devices must be in good condition and function properly.
- Ensure sufficient lighting of the surroundings.
- Keep the workplace clean.

2.2. INDOOR & OUTDOOR USE

The ECO2JET® is designed for outdoor use and use in well-ventilated indoor spaces.

⚠ DANGER

Do not use the ECO2JET® in poor ventilated confined spaces. Exposure to high levels of vapors or smoke can cause skin irritation and may obscure visibility.

NOTICE

Provide the machine with extra protection in heavy rain.

2.3. RIGGING

Please follow the European and national guidelines for safe rigging and trussing.

2.4. NOISE LEVELS







The environmental noise level as measured at the ear is 95 dB(A). This level of noise is only reached during the short instances that the output is active. Always wear hearing protection when you are within 5 meters of the machine during operation.

2.5. SAFETY SYMBOLS

Symbol	Meaning	Position
	Read the manual carefully before use!	On the control panel.

Safety symbols

2.6. SAFETY WARNINGS

 WARNING	Using a damaged or an improper installed machine can lead to death, serious injury or property damage. Always inspect the machine thoroughly before operation.
 WARNING	Do not install the machine if you are unsure of the safety of a possible installation.
 WARNING	When a safety wire is required, use a safety wire with an emergency link that is tightened with a wrench. Handtight is not enough.
 WARNING	Make sure the structure intended to hold the machine is calculated for the weight. The ECO2JET® is a heavy machine. Overhead rigging requires extensive experience in calculating load limits, installation materials, and performing periodic safety inspection. Only qualified personnel is allowed to perform this.
 WARNING	Only hoist the machine using the safety steel backdish. Do not hoist using the handles or tension straps.
 WARNING	The safety steel and the emergency link need to have a minimal workload of 40 kg.
 WARNING	Missing or obscured safety symbols on the machine can lead to death or serious injury. Make sure all safety symbols are correctly in place, see section 2.5.

⚠ WARNING

Always create a safety zone around the machine with a radius of 0.3 meter. Make sure that the area is clear of unauthorized persons, animals and objects. Not doing so can result in death or serious injury. Note that overlap of safety zones in a setup with multiple machines is allowed, as long the air grilles are not obstructed.

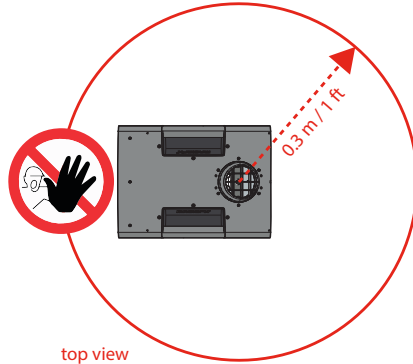

⚠ WARNING

Always keep the output zone as shown in the image below clear of all people, animals and objects. Not doing so may result in death or serious injury. Note that the zone shifts accordingly when the machine is installed in a tilted position on the stage.

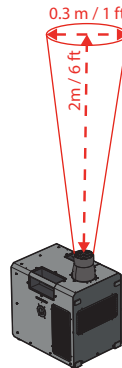

⚠ WARNING

A poorly mounted machine will come loose when the machine is operated. This can lead to death, serious injury and/or property damage. Always inspect if the machine is mounted firmly and correctly as according to the instructions in this manual.

⚠ DANGER

Do not mount the ECO2JET® to the truss sideways. Only suspend the ECO2JET® from the truss.

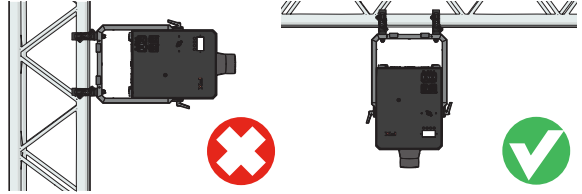

⚠ WARNING

Make sure there are no objects near the output that can be damaged or overthrown by the ECO2JET®.

⚠ WARNING

If non regular sounds come out of the nozzle when the unit is enabled, stop operation immediately and disconnect power. Please contact the service department of MAGIC FX.

⚠ CAUTION

Make sure that the Fluid Mesh Filter G 1/4" is installed.

⚠ CAUTION

For your safety, when operating in Test Mode, all authorized personnel are required to wear appropriate safety gear, including protective eyewear and hearing protection.

⚠ CAUTION

Make sure that the air grilles of the ECO2JET® are not blocked.

⚠ CAUTION

If anything falls into the output opening, immediately cease operation. Contact MAGIC FX.

3. INSTALLATION AND USE

The ECO2JET® can be positioned on a stage or floor or can be mounted on a truss.

3.1. MOUNT ON A STAGE

The ECO2JET® can be placed directly on a stage or floor on its rubber feet or tilted using the ECO2JET® Bracket.

⚠ WARNING

The machine may not be placed on its side.

⚠ CAUTION

Keep a minimum distance of 30 cm between the machines.

3.1.1. WITHOUT A BRACKET

When placing multiple machines together on stage or floor, make sure the air grilles are not blocked.

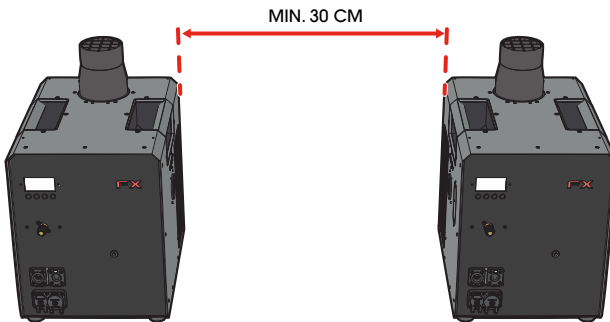

3.1.2. WITH AN ECO2JET® BRACKET

The ECO2JET® can also be used on stage with an ECO2JET® Bracket.

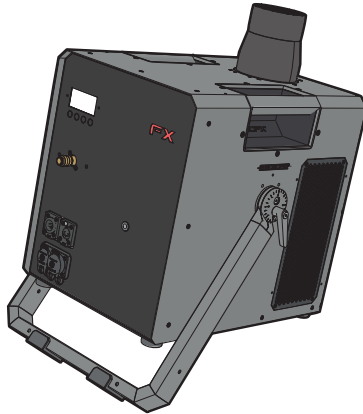

More information on using the ECO2JET® Bracket can be found in the ECO2JET® Bracket accessory manual.

3.2. MOUNT ON A TRUSS

The following options are available for truss mounting:

- ECO2JET® Bracket (MFX1802)
- Omega Brackets (MFX1804)
- Doughty Quick Trigger Clamp (100 kg) M10 (MFX3104)
- Doughty Half Coupler (100 kg) M10 (MFX3106)

Use the Omega Brackets or the ECO2JET® Bracket to hang the ECO2JET® upside down.

The ECO2JET® is a heavy machine. In static situations, using only one clamp is possible. It is however recommended to use two clamps.

⚠ CAUTION

Installing the ECO2JET® in a motion truss is not recommended.

⚠ CAUTION

Keep a minimum distance of 30 cm between the machines.

3.2.1. MOUNT WITH OMEGA BRACKETS

The ECO2JET® can be suspended from a truss by attaching Omega Brackets with clamps to the bottom of the machine.

1. Flip the ECO2JET® upside down. Be careful with the nozzle.
-

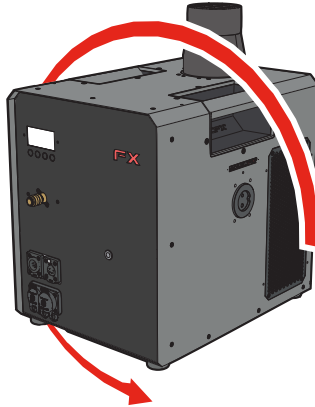

2. Mount clamps (MFX3104 or MFX3106) to the Omega Brackets (MFX1804) using the provided bolts and nuts.
 3. Attach the Omega Brackets to the quarter turn receptacles in the ECO2JET®.
-

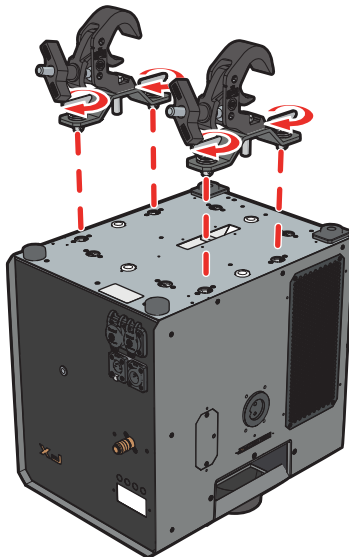

4. Mount the ECO2JET® in a horizontal position only onto a horizontal truss.

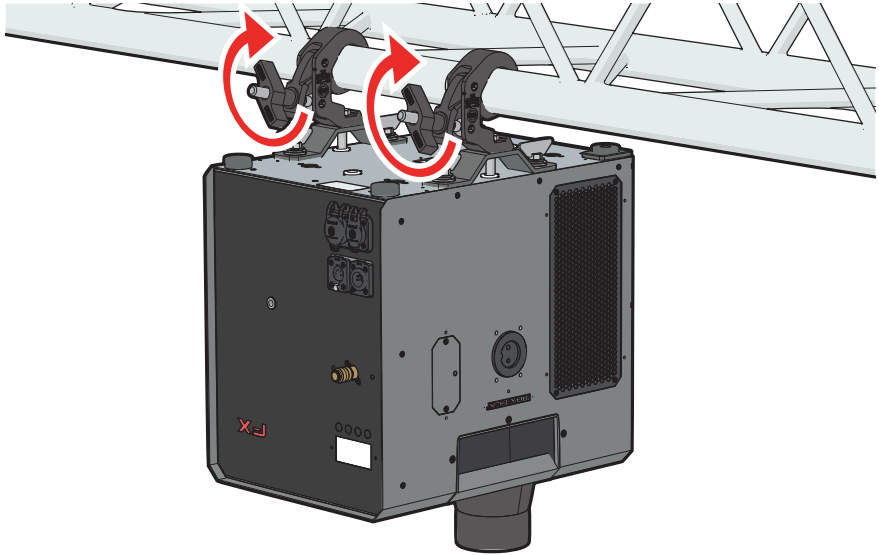

⚠ CAUTION

Take the recoil of the ECO2JET® into account. Make sure the construction is prepared for the counter force of firing the effect.

5. Secure the ECO2JET® onto the truss with use of a safety wire on the bottom of the ECO2JET®. Make sure the safety wire is as short as possible. If needed, wind the cable around the truss to pull it tight.

⚠ CAUTION

The safety steel and the emergency link need to have a minimal workload of 40 kg.

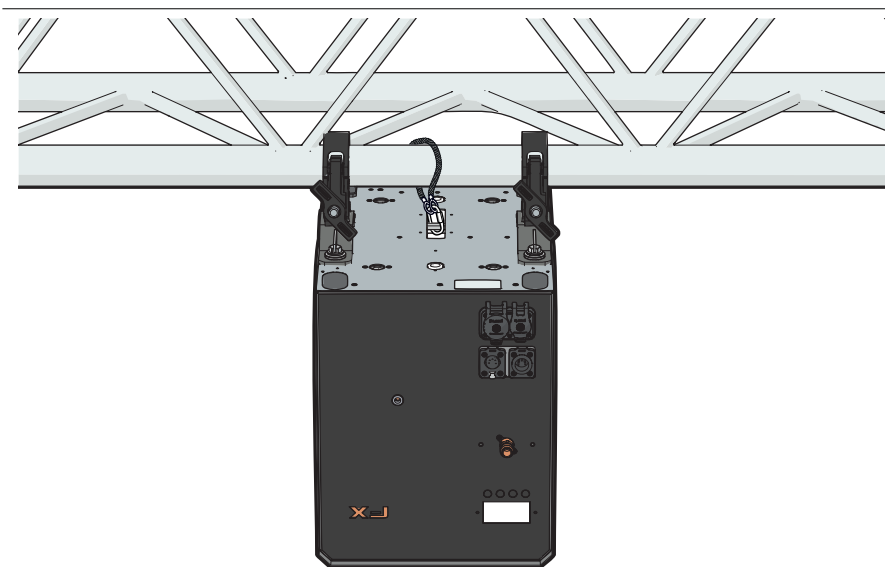

-
6. By default, the machine is programmed to autoflip the display. However, to preserve a particular configuration use “flip mode” in the menu. This will allow to preserve a desired setting without any automatic adjustments.
 7. Make sure that the installation complies with all relevant safety requirements, such as creating a safety zone and a free output zone, see Section 2.6.

3.2.2. MOUNT WITH CLAMPS ONLY

This chapter describes the 100 kg Doughty Quick Trigger Clamps (MFX3104) as an example. The 100 kg Doughty Half Couplers (MFX3106) follow a similar process.

1. Attach the clamps (MFX3104 or MFX3106) to the M10 mounting holes on the bottom side of the ECO2JET® with the provided bolts.

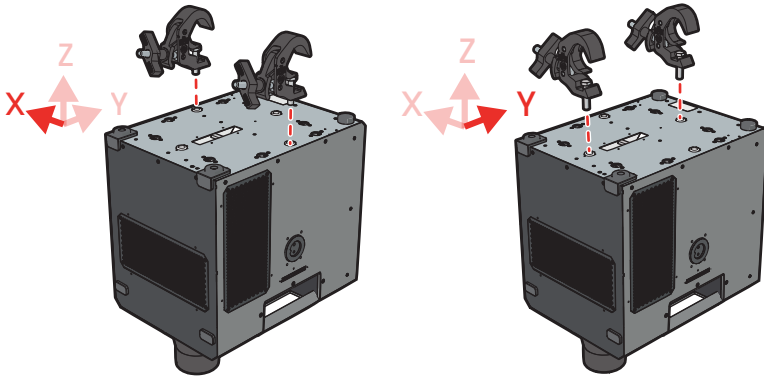

2. Mount the ECO2JET® in a horizontal position onto a horizontal truss. Vertical truss mounting is not permitted.

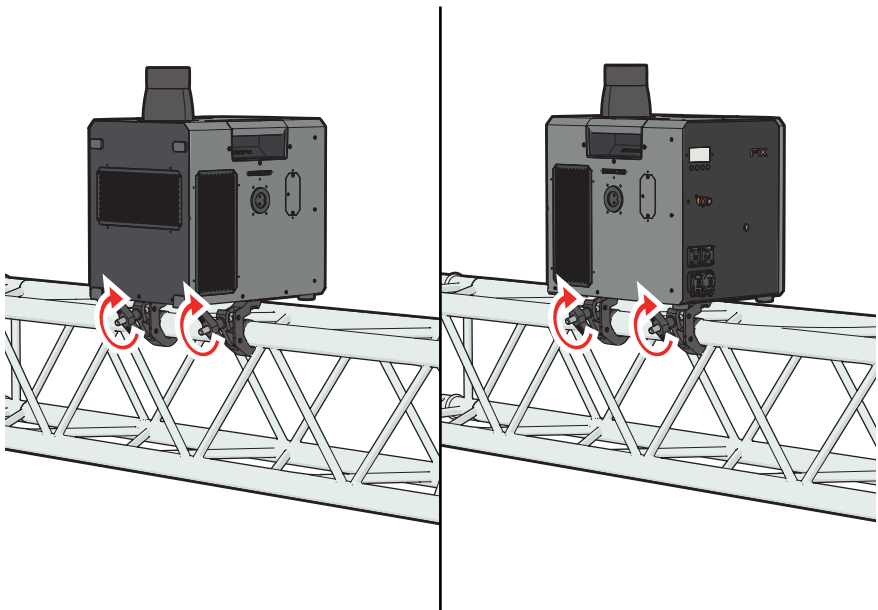

⚠ CAUTION

Take the recoil of the ECO2JET® into account. Make sure the construction is prepared for the counter force of firing the effect.

3. Secure the ECO2JET® onto the truss with use of a safety wire on the bottom of the ECO2JET®. Make sure the safety wire is as short as possible. If needed, wind the cable around the truss to pull it tight.

⚠ CAUTION

The safety steel and the emergency link need to have a minimal workload of 40 kg.

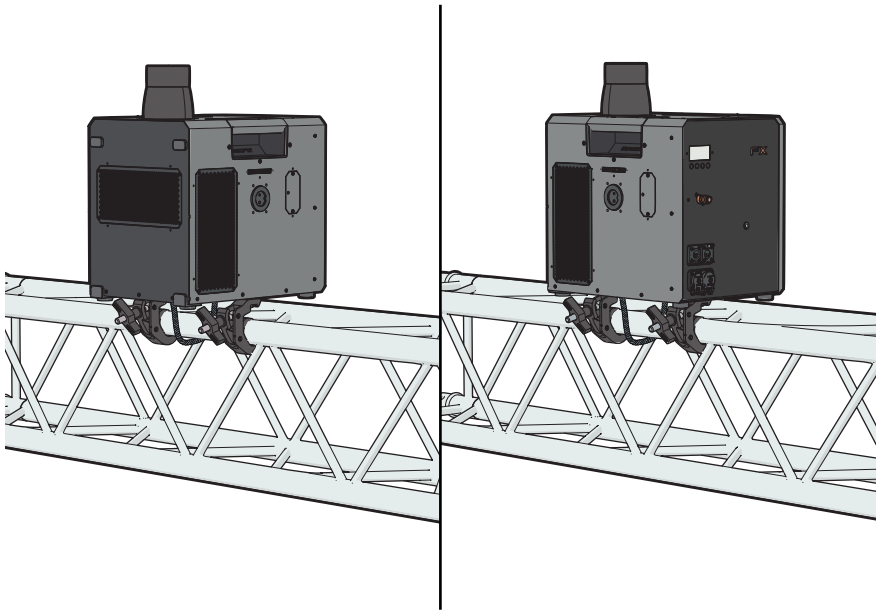

4. By default, the machine is programmed to autoflip the display. However, to preserve a particular configuration use “flip mode” in the menu. This will allow to preserve a desired setting without any automatic adjustments.
5. Make sure that the installation complies with all relevant safety requirements, such as creating a safety zone and a free output zone, see Section 2.6.

3.2.3. MOUNT WITH AN ECO2JET® BRACKET

The ECO2JET® can also be installed on a truss using an ECO2JET® Bracket.

NOTICE

The ECO2JET® Bracket is an optional accessory and is not included.

More information on using the ECO2JET® Bracket can be found in the ECO2JET® Bracket accessory manual.

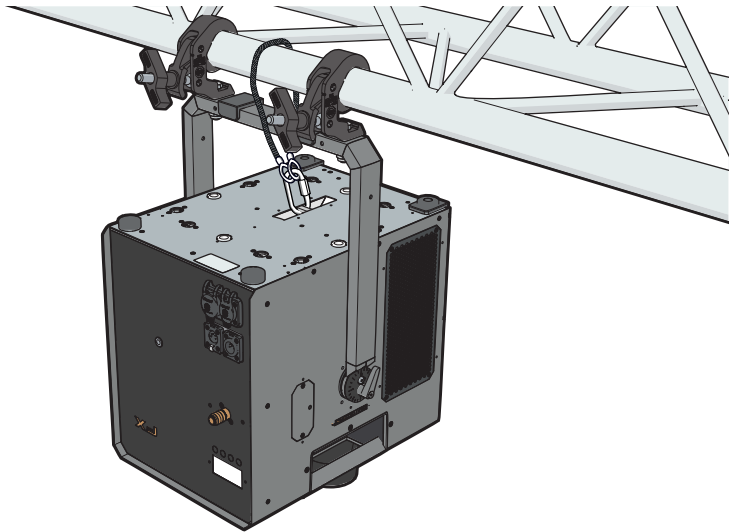

CAUTION

The safety steel and the emergency link need to have a minimal workload of 40 kg.

3.3. (RE)PLACE THE FLUID CAN

WARNING

Do not use other fluids than those that are approved and supplied by MAGIC FX, see section 1.4. Always follow the instructions as noted on the fluid can. The warranty is void if other fluids are used.

1. Make sure that the machine is not in operation. The FX LED indicator is off.
2. Place the fluid can including its ECO2JET® Fluid Can Lid Assembly (ASS90100) in the vicinity of the machine, for example in the MAGICFX® 5L Fluid Can Bracket (MFX3109).
3. Connect the Fluid can including its ECO2JET Fluid Can Lid Assembly (ASS90100) by using the quick connector.

NOTICE

With a MAGICFX® ECO2JET® Extension Hose (MFX1805 or MFX1806), the hose can be extended. The maximum (height) distance between the fluid can and the ECO2JET® is 2 meters.

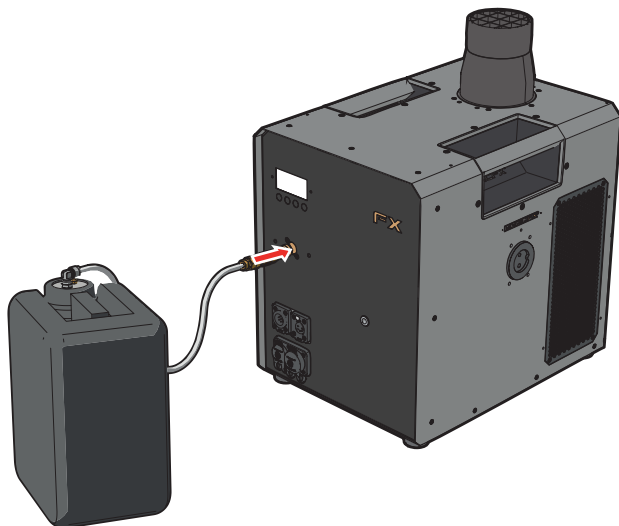

⚠ WARNING

Only disconnect the fluid can when the device is not enabled or the power is disconnected. This is necessary for the system's pressure being able to release.

NOTICE

Make sure the hose is not pinched.

3.4. MOUNT THE ATTACHABLE FLUID CAN

Instead of connecting a fluid can, an Attachable Fluid Can (MFX1803) can be mounted to the back side of the ECO2JET®.

More information on using the 2L Attachable Fluid Can can be found in the 2L Attachable Fluid Can accessory manual.

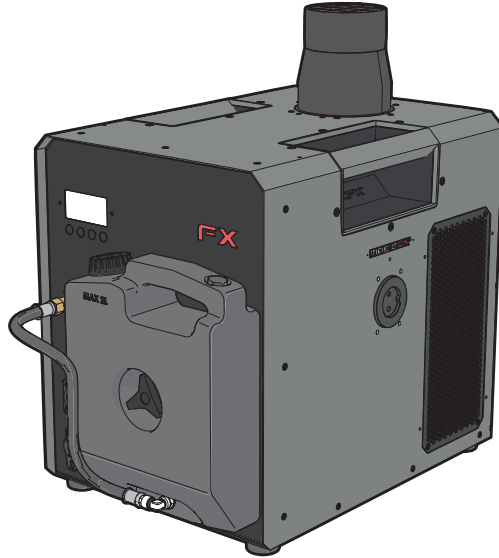

3.5. CONNECT DMX AND POWER

1. Connect a power cable with a Powercon TRUE1 Female connector to the power input. Connect the other end of the power cable to a 210–240 Vac (50 – 60 Hz) power source.
2. Connect the female connector of a 5-pole DMX cable in the DMX input. Connect the other end of the DMX cable to your DMX controller.
3. Optionally link the power output and the DMX output through to another machine.
4. Optionally set the heat-up power mode.

NOTICE

Always plug in a DMX Terminator into the DMX output of the final unit in the control sequence. Using a DMX Terminator improves signal reliability.

3.6. SETTING THE HEAT-UP POWER MODE

The heat-up power mode can be changed to heat up faster using the FULL heat-up power mode. This mode allows less machines on a single power group. The heat-up time is longer in the ECO power mode, both in advance and inbetween firing effects. The effect itself remains the same. There are two heat-up power modes:

Mode	Power	Heat-up time
ECO	1.5 kW	18 min
FULL	3.5 kW	9 min

Heat-up power modes

Regardless of the power mode selected, the maximum duration of the effect is 8 seconds. Once this time elapses, the effect will automatically cease. To initiate the effect again, you will need to deactivate and then reactivate the Effect trigger. This will enable you to restart the effect and experience it once more.

NOTICE

The effect is the same in each heat-up power mode.

NOTICE

Keep in consideration that during the effect the heater will cool down and the interval between two equal effect durations not only depends on the effect time used, but also on the set heat-up power mode.

3.7. PRIME THE ECO2JET®

The ECO2JET® is equipped with a priming function designed to eliminate any trapped air within the system and connected hoses. It is advisable to prime the ECO2JET® before each event if it is positioned at a height difference of +1m relative to the attached fluid canister, or if a new extension hose is used.

1. Make sure the device is heated up and a fluid canister is connected and the heater is not disabled.
2. Set the DMX value for the enable channel between 200 and 255 to prime.
3. Set the DMX value for the start channel between 100 and 154 to prime.
4. The FX LED indicator will start blinking and some smoke will be generated by the device.
5. When the FX LED indicator solidly lights up, the priming is done.
6. The enable and start channel may now be deactivated or the user may continue with Chapter 3.8. Blast with DMX.

NOTICE

The device can also be operated using the Test Mode menu. Keep safety regulations in mind when operating manually.

3.8. BLAST WITH DMX

⚠ CAUTION

Make sure that the air grilles of the ECO2JET® are not blocked.

NOTICE

In case the ambient temperature reaches unusually high levels, the fan might engage at a low speed to prevent the machine from overheating.

1. Make sure that the direct output is free from persons, animals and objects.
 2. Set the DMX value for the enable channel between 100 and 154. The system is pressurised, the fan is on, and the FX LED indicator lights up.
 - a. The device can also be pre-enabled to pressurize the system prior to enabling. To trigger the effect the device first must be fully enabled. Refer to Chapter 1.6.DMX control for the exact DMX values.
 3. Set the DMX value for the start channel between 200 and 255 to shoot.
 4. Enjoy the view! The effect can be activated until the heater temperature is too low, the effect and FX LED indicator then stop. The FX LED indicator lights up again when the temperature is high enough. The effect can then be reactivated.
-



-
5. When you have finished blowing everyone's minds, deactivate the start channel.
 6. Deactivate the enable address.

NOTICE

The device can also be operated using the Test Mode menu. Keep safety regulations in mind when operating manually.

3.9. CLEAN UP

⚠ CAUTION

The fluid in the machine heats up and is pressurised during operation, and unused hot fluid is returned into the fluid can. Be aware the quick connector can be hot while disconnecting the Fluid Can Lid Assembly of the Attachable Fluid Can.

⚠ CAUTION

The heater and nearby surfaces of the machine get hot during operation. Do not touch these parts during or directly after operation. Wait until the machine has cooled down.

1. Make sure that the ECO2JET® is not in operation (FX LED indicator is off) and is cooled down.
2. Disconnect the cables.
3. Disconnect the fluid hose using the quick connector and remove the fluid can.
4. Dismount the machine.

4. TROUBLESHOOTING

In case the display shows one of the following error/alarm or warning codes, act accordingly:

Code	Meaning	Solution
010	Heat-up error	<ul style="list-style-type: none">• Contact MAGIC FX.
011	Fan controller error	<ul style="list-style-type: none">• Power cycle the device. If it happens again, contact MAGIC FX.
015	Fan RPM error	Fan not running at the desired speed. <ul style="list-style-type: none">• Power cycle the device.• Check if the fan is clear of any objects.• If it happens again, contact MAGIC FX.
018	Pressure problem	<ul style="list-style-type: none">• Make sure that the fluid can is not empty.• Make sure that all hoses are connected properly and are not pinched.• Make sure all fittings are leakproof.• Make sure that the Fluid Mesh filter G 1/4" is not clogged.
020	Pressure sensor failure	<ul style="list-style-type: none">• Contact MAGIC FX.
100	DMX address conflict	<ul style="list-style-type: none">• Change either the DMX safety or the DMX start address
104 - 107	Thermocouple error	<ul style="list-style-type: none">• The thermocouple is not attached correctly. Contact MAGIC FX.
120	Heater overheat error	<ul style="list-style-type: none">• Contact MAGIC FX.
128	Fan communication error	<ul style="list-style-type: none">• Power cycle the device. If it happens again, contact MAGIC FX.

Troubleshooting

Code	Meaning	Solution
129	Hardware overheat error	Internal device hardware is overheated. <ul style="list-style-type: none"> • Make sure the device is used within its operating temperature.
130	Temperature sensor fault	Hardware temperature sensor fault. <ul style="list-style-type: none"> • Power cycle the device. If it happens again, contact MAGIC FX.
208	Temperature overheat warning	<ul style="list-style-type: none"> • Make sure the device is used within its operating temperature.
211	Heat-up warning on	<ul style="list-style-type: none"> • If it happens often, contact MAGIC FX.
212	Hardware overheat warning	<ul style="list-style-type: none"> • Make sure the device is used within its operating temperature.
213	Heater off warning	<ul style="list-style-type: none"> • This warning is displayed when the user disabled the heater.

Troubleshooting

Always contact MAGIC FX if any malfunctions or (unlisted) errors occur that cannot be solved with the instructions as described in this manual.

In this stage, MAGIC FX appreciates it if the occurrence of errors/warnings will be reported as detailed as possible.

5. MAINTENANCE

To achieve the maximum service life of the ECO2JET® you must regularly clean the ECO2JET® and test if it is functioning correctly.

Contact MAGIC FX if the ECO2JET® is not functioning correctly.

⚠ DANGER

Do not replace parts yourself other than specified in this chapter; always consult MAGIC FX.

⚠ DANGER

Always cut off the power before performing maintenance.

5.1. REPLACE THE AIR FILTER

1. Remove the air grille using a T10 Torx screwdriver.
 2. Remove the old air filter from the air grille.
-

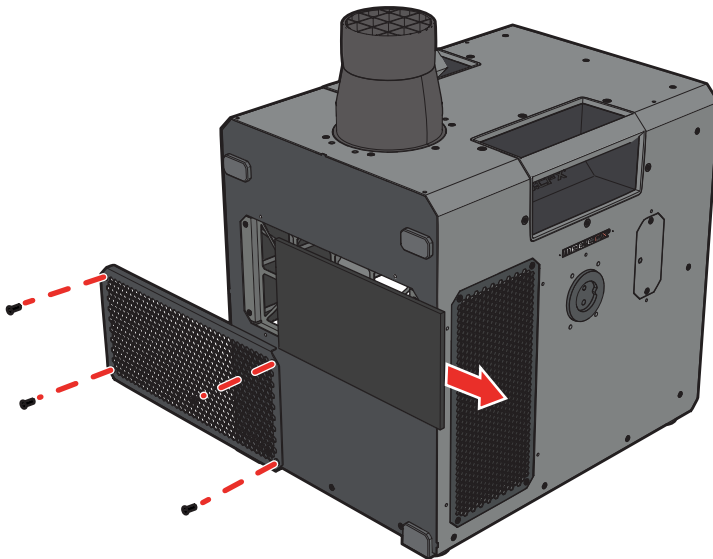

3. Place the replacement air filter (ASS02427) in the air grille.
4. Re-attach the air grille using a T10 Torx screwdriver.

5.2. REPLACE THE FLUID MESH FILTER

NOTICE

Replace the Fluid Mesh Filter at least once a year.

1. Place the ECO2JET® on a table with the service lid pointed towards the floor. Make sure the service lid protrudes over the edge of the table so you can access it.

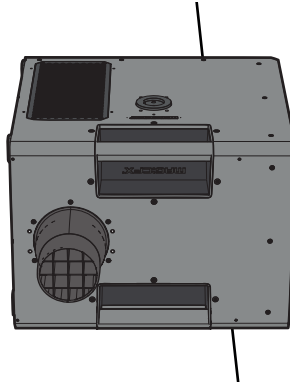

2. Remove the service lid using a T10 Torx screwdriver.
3. Remove the large plug using a size 8 hex key.
4. Remove the Fluid Mesh Filter G 1/4" using a large flat screwdriver.

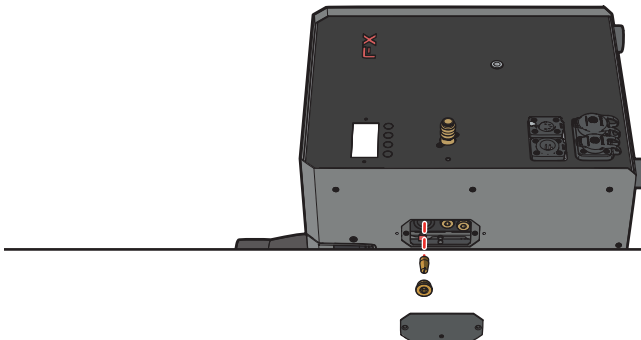

5. Attach the replacement Fluid Mesh Filter G 1/4" (PART02402) using a large flat screwdriver.
6. Re-attach the large plug using a size 8 hex key. Use a torque wrench set to 16 Nm if available.
7. Re-attach the service lid using a T10 Torx screwdriver.

6. CORRECT DISPOSAL



This symbol on the product and / or accompanying documents means that used electrical and electronic products should not be mixed with general household waste. For proper treatment, recovery and recycling, please take this product to designated collection points where it will be accepted free of charge. Alternatively, in some countries you may be able to return your products to your local retailer upon purchase of an equivalent new product. Disposing of this product correctly will help save valuable resources and prevent any potential negative effects on human health and the environment, which could otherwise arise from inappropriate waste handling. Please contact your local authority for further details of your nearest designated collection point. Penalties may be applicable for incorrect disposal of this waste, in accordance with your national legislation.

7. EC DECLARATION OF CONFORMITY

MAGIC FX B.V. declares as manufacturer and composer of the technical construction file that the product with the following specifications:

Name machine	: ECO2JET®
Type	: MFX1801
Voltage	: 210-240 VAC 50/60Hz
Serial number	: on product
Year of construction	: on product

Is in conformity with the minimal safety regulations as stated in the following directive(s):

- Directive 2014/35/EU Low Voltage (LVD)
- Directive 2014/30/EU Electromagnetic Compatibility (EMC)
- Directive 2011/65/EU Restriction of the use of certain Hazardous Substances (RoHS)
- Directive 2012/19/EU Waste Electrical & Electronic Equipment (WEEE)

The following harmonized standards were applied:

- NEN-EN-IEC 62368-1:2020 Audio/video, information and communication technology equipment - Part 1: Safety requirements
- NEN-EN-IEC 61000-6-1:2007 Electromagnetic compatibility (EMC) - Part 6-1: Generic standards - Immunity for residential, commercial and light-industrial environments
- NEN-EN-IEC 61000-6-3: 2007 Electromagnetic compatibility (EMC) - Part 6-3: Generic standards - Emission for residential, commercial and light-industrial environments

- Original declaration of conformity
- Translation of the original declaration of conformity

Name manufacturer	: MAGIC FX B.V.
Address	: Schouwrooij 27, 5281 RE BOXTEL
Country	: The Netherlands
CEO	: B. Veroude
Date	: 26-3-2024
Signature	



MAG:CFX[®]

WWW.MAGICFX.EU

